

Features:

- 98dB sensitivity 1W/1m
- 500W Power handling
- Extremely light weight of 3.5kg
- 3" copper sandwich voice coil for low power compression
- Double treated cone for water protection
- Neodymium magnet system
- Triple aluminum demodulating rings for ultra low distortion
- Optimal for compact 2- or 3-way systems

SPECIFICATIONS

APPLICATION	Low-Middle	
Nominal impedance	Ohm	8
Power handling AES noise	W	500
Sensitivity (1W/1m)	dB	98
Frequency response	Hz	45 - 2500
Voive coil diameter	mm	77 (3")
Voice coil material		Cu
Voice coil winding depth	mm	19
Magnet gap depth	mm	8
Basket		Cast Aluminum
Effect. diaphragm diameter D	mm	260

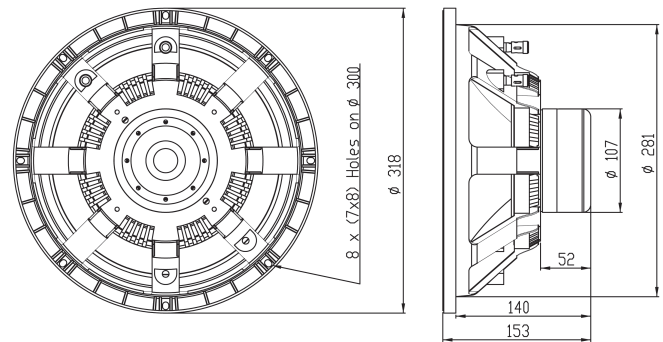

THIELE - SMALL PARAMETERS			
Resonance frequency	Fs	Hz	44.7
DC resistance	Re	Ohm	5.70
Mechanical Q factor	Qms		5.1
Electrical Q factor	Qes		0.26
Total Quality factor	Qts		0.25
Equivalent volume	Vas	L	72.7
Moving mass	Mms	kg	0.068
Mechanical compl.	Cms	mm/N	0.18
BL factor	BL	Tesla m	20.60
Effective piston area	Sd	m ²	0.0531
Max. linear excursion	Xmax	mm	± 3.5
Voice coil inductance	Le1k	mH	0.6
	Le10k	mH	0.39

Frequency response measured 100W (28.3V) at 1m in a closed enclosure of 50 litre in an anechoic chamber incl. 2nd and 3rd harmonic distortion raised 20dB.

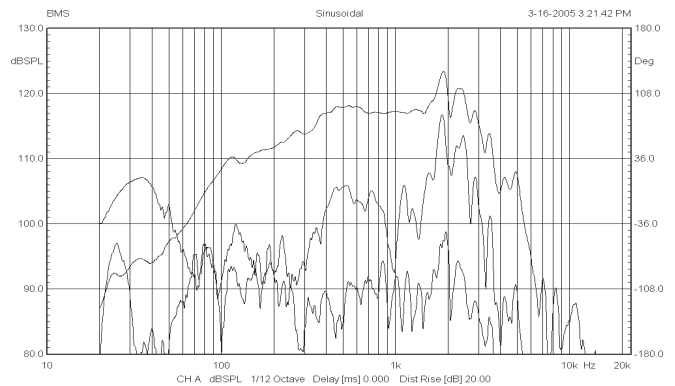

MOUNTING INFORMATION		
Overall diameter	mm	318
Mounting holes diameter	mm	8 x (7 x 8)
Bolt circle diameter	mm	300
Baffle cut-out diameter	mm	284
Overall depth	mm	145
Net weight	kg	3.5

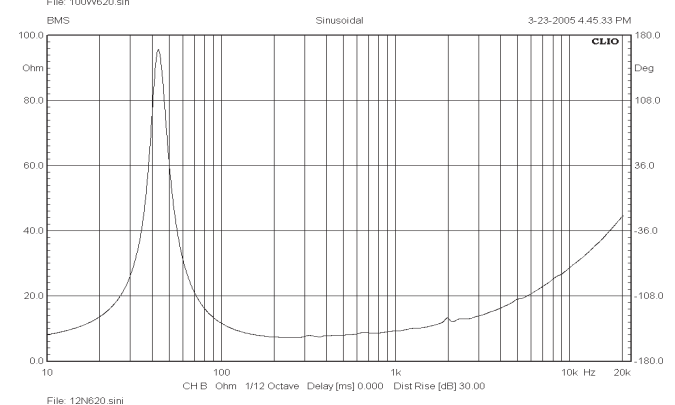

Recommended reflex enclosure:

17L/62Hz, -3dB=75Hz, BRD=80mm/148mm long

25L/60Hz, -3dB=63Hz, BRD=100mm/177mm long